

The background features a vibrant green color scheme. At the top, there are several bright green leaves with visible veins, some in sharp focus and others blurred. Below the leaves, the background transitions into a pattern of concentric, light green ripples, suggesting water. The overall aesthetic is clean, fresh, and natural.

# AutoBott

## Final Presentation

### **Group 2:**

David Rooney, C.P.E.

Steven Lo, C.P.E.

Eric Velazquez, E.E.

Antonio Orosa, E.E.

# Motivation

- A vast majority of crops are grown outside, where they are exposed to dramatic climate changes and insects
- Plants are becoming less likely to thrive in the record breaking seasonal temperatures around the world
- Water is a scarce resource and not easily accessible in certain areas of the globe

# Goals and Objectives

- By using hydroponics, water is being conserved within the system
- Plants will be grown indoors
- Plants can grow year round
- Maximize harvest or bloom
- Eliminate the chance of diseases and fungus growing on the plants

# AutoBott: An Automated Botanical System

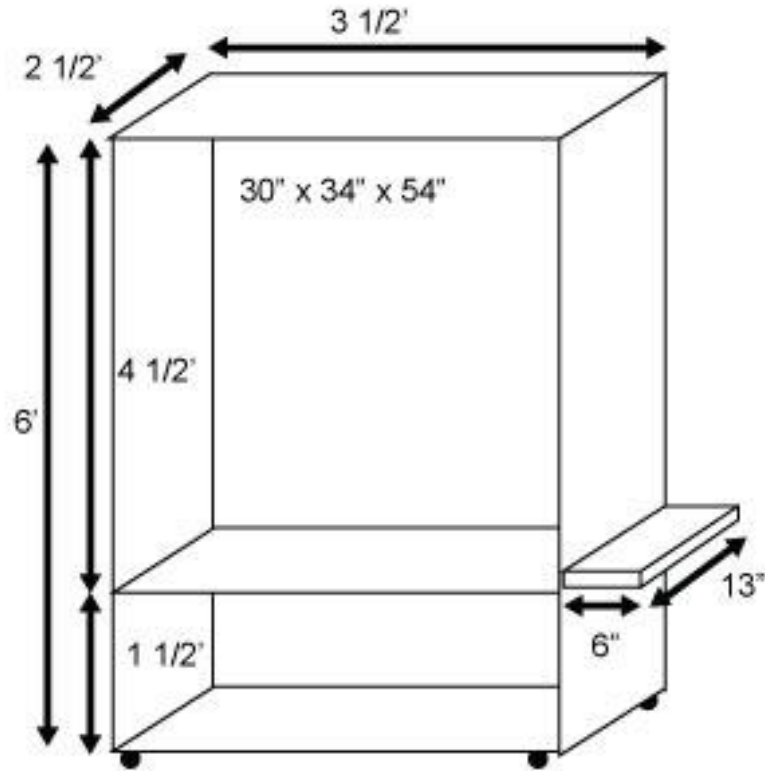

## Physical Enclosure

- Main Plant Compartment
  - Will house Lights, Fan, Plants, and majority of hydroponic system
  - Will be coated with a layer of Mylar: a reflective material made into sheets that also has insulating properties
- Water/Nutrient Compartment
  - Will house water and nutrient reservoirs
  - Water pump and Nutrient pumps
- Electronics Compartment
  - Will hold PCB board and components

# AutoBott: An Automated Botanical System (cont.)

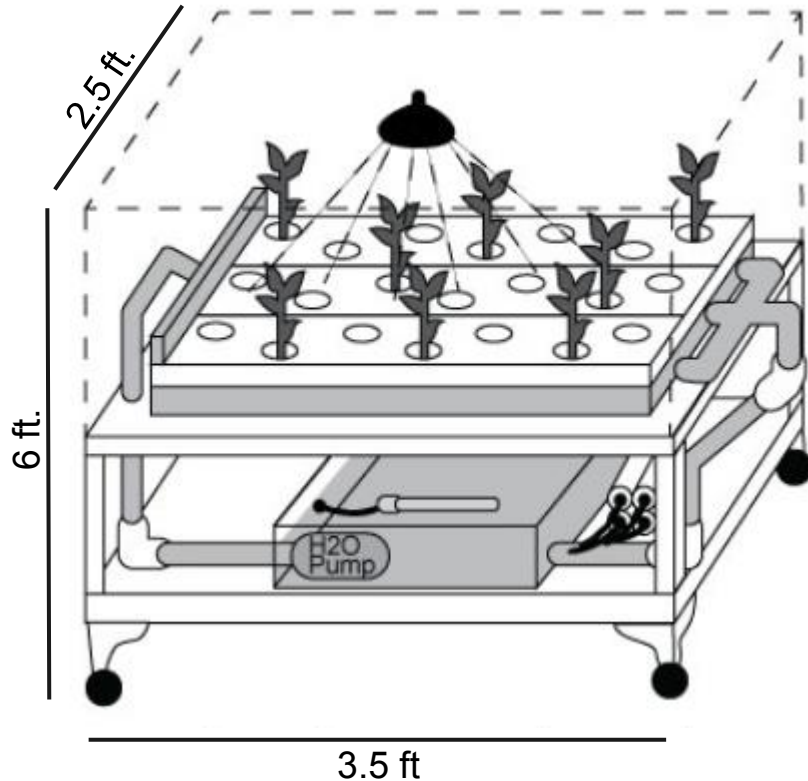

## Hydroponic System

- Nutrient Film Technique
  - Pump will run constantly, providing the plants with a stream of nutrient solution
  - Plants will sit in individual grow cups along the top of each plant tray, where their roots will absorb the nutrients
  - Once the nutrient solution leaves the plant trays, it will drain back to the reservoir
- Water/Nutrient Compartment
  - pH, EC, and water level sensors will regulate our water reservoir
  - As the nutrient solution is returning to the reservoir, our pumps will automatically inject nutrients, and pH altering solution as our system needs it

# Specifications

Sensors	Unit of Measure	Accuracy
pH Levels	pH	Range within .5 pH
EC Levels	ms/cm (siemens per meter)	Range within 20 ms/cm
Temperature	°F	Range within 5°F
Humidity	Percentage	Range within 8%

Component	Parameter	Design Specification
Web application	Update time	30 min
Water pump (full cycle)	Circulation	2 hours
LED Lights	Light exposure	6000 Lumens per square foot

# Overall Block Diagram

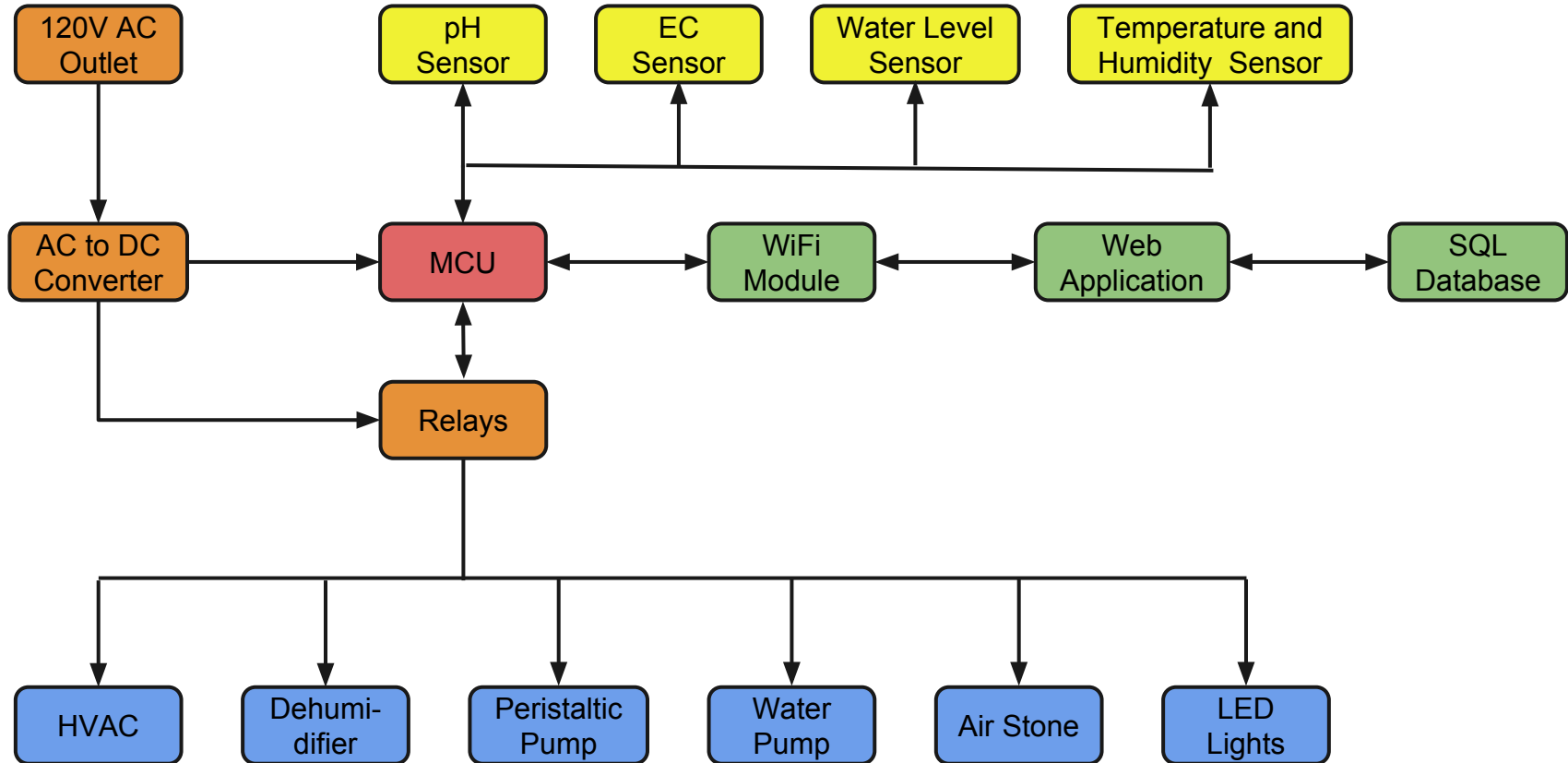

# Wireless Communication Module

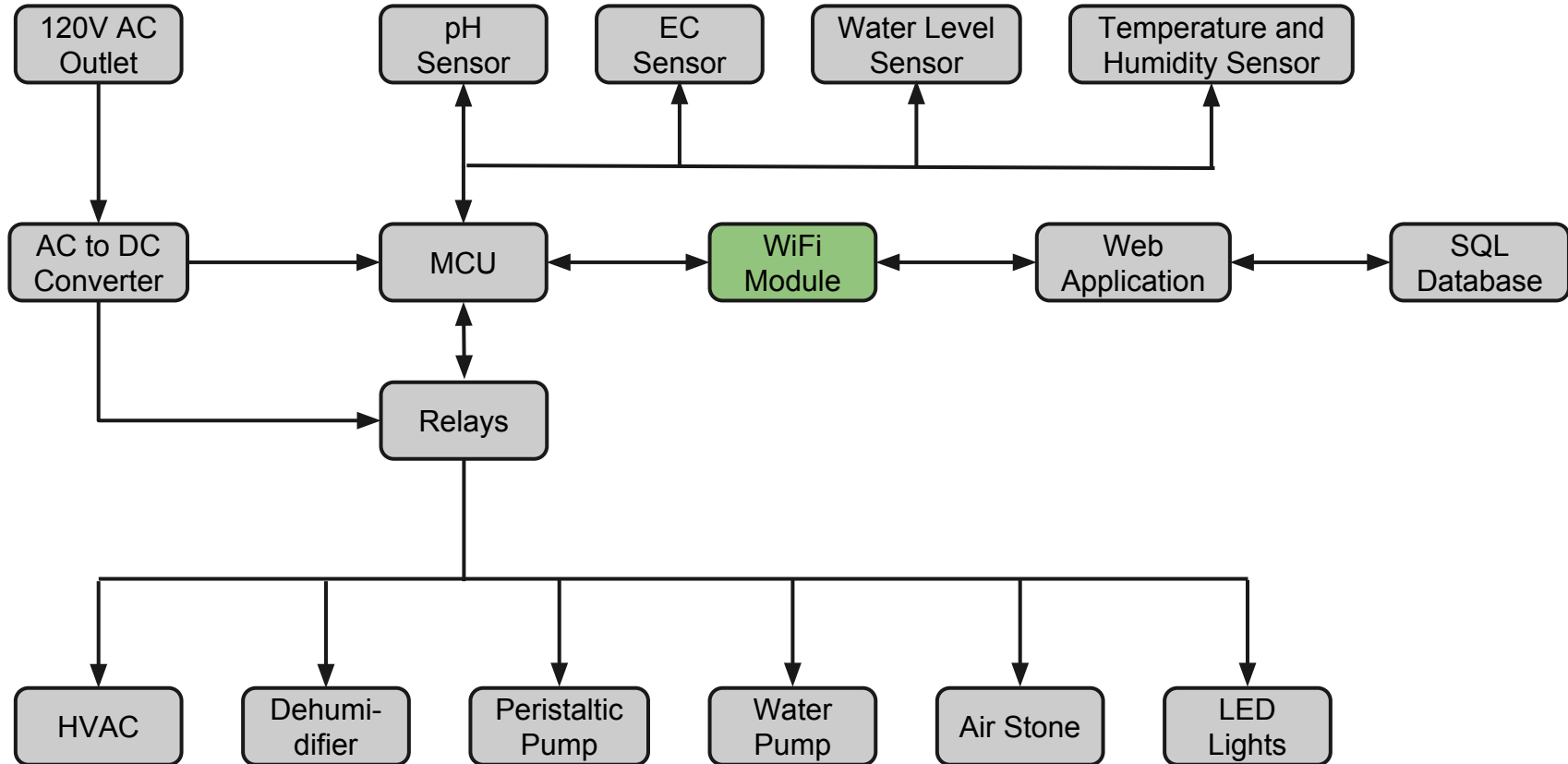



# Wireless Communication Module

## Wifi vs. Bluetooth vs. Zigbee

- Wifi has high data transfer rates and good range, but uses more power than other modules
- Bluetooth has very short range and can connect to a maximum of 7 other devices
- ZigBee is designed for reliable wirelessly networked monitoring and control networks. Low power, long range, and can connect to over 65,000 devices

Standard	Bluetooth	Zigbee	Wi-Fi
IEEE spec..	802.15.1	802.15.4	802.11a/b/g
Frequency band	2.4GHz	868/915 MHz; 2.4 GHz	2.4 GHz; 5 GHz
Max signal rate	1 Mb/s	250kb/s	54Mb/s
Nominal range	10 m	10-100 m	100 m
Nominal TX power	0 - 10 dBm	(-25) - 0 dBm	15 - 20 dBm
Number of RF channels	79	1/10;16	14(2.4GHz)
Channel bandwidth	1MHZ	0.3/0.6 MHz; 2 MHz	22MHz
Modulation type	GFSK	BPSK (+ ASK), O-QPSK	BPSK, QPSK COFDM, CCK, M-QAM
Spreading	FHSS	DSSS	DSSS, CCK, OFDM
Coexistence mechanism	Adaptive freq. hopping	Dynamic freq. selection	Dynamic freq. selection transmit power control (802.11h)
Basic cell	Piconet	Star	BSS
Extension of the basic cell	Scatternet	Cluster tree-mesh	ESS
Max number of cell nodes	8	> 65000	2007
Data protection	16-bit CRC	16-bit CRC	32-bit CRC

# Wi-Fi: HLK RM04

## Hi-Link HLK RM04 Wi-Fi Module

- Follows IEEE Wireless Standards 802.11n, 802.11g, and 802.11b
- Runs on 5V (350mA), and range up to 100 meters
- Can connect with up to 20 devices
- Will communicate with our mcu and share the sensors' data readings wirelessly through the standard **2.4 GHz frequency band**, transferring data at a **Max of 150 Mbps**
- We are using the provided external antenna, and powering the module from our PCB board

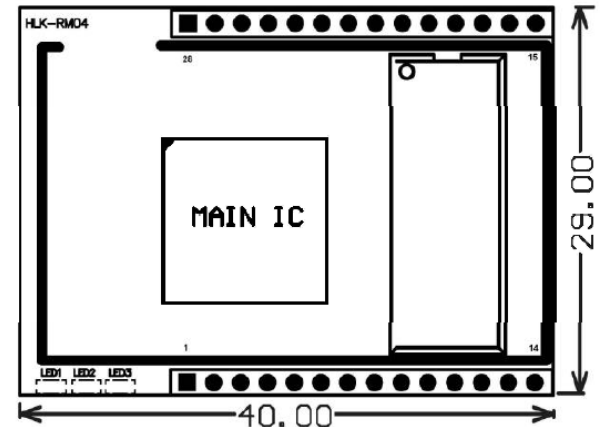

# Transmitting Sensor Data

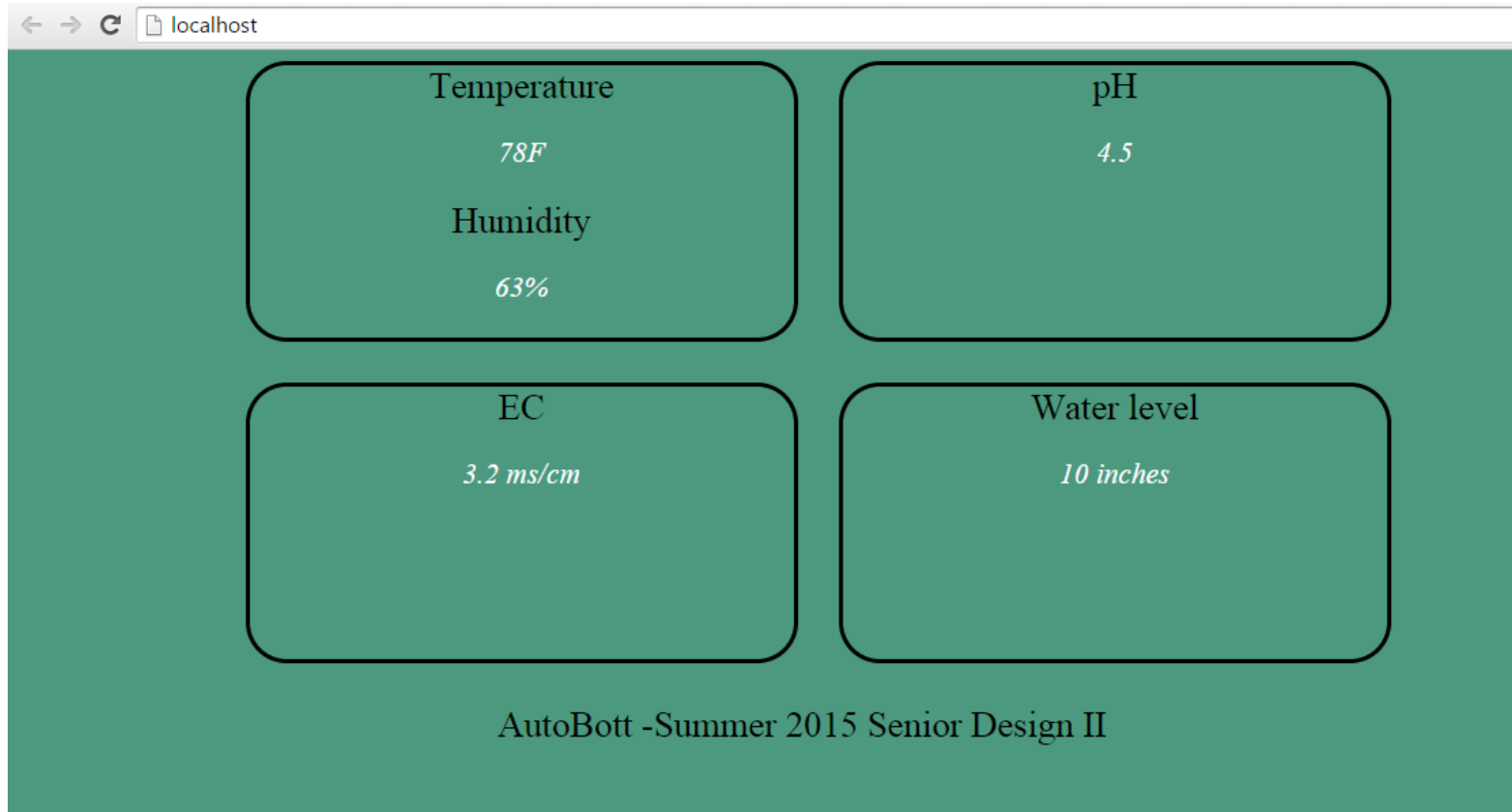

AutoBott -Summer 2015 Senior Design II

# Sensors

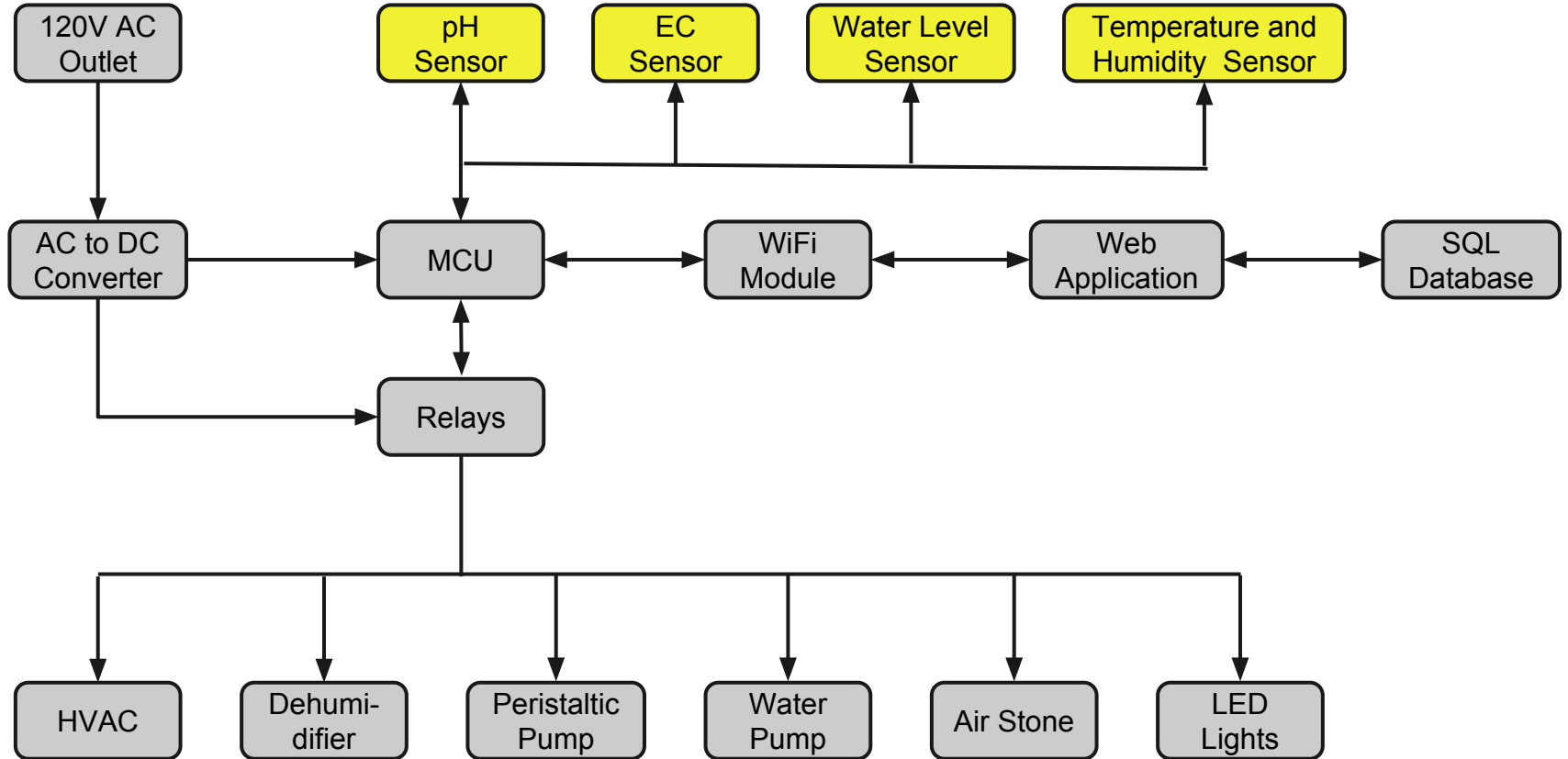

# Analog pH Meter Kit

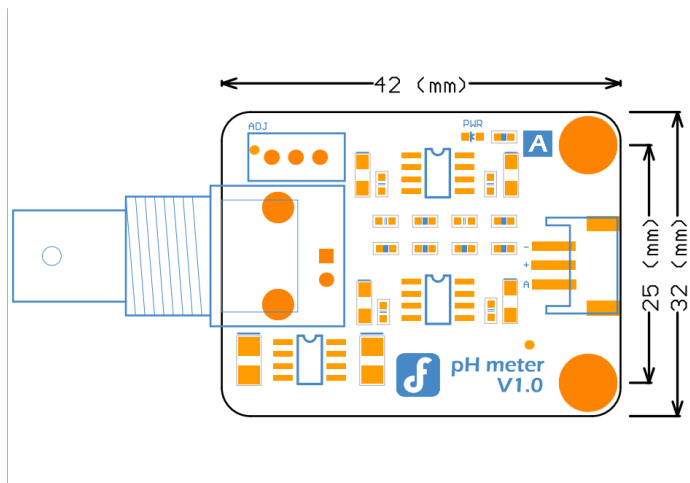

*PCB Design Layout from DFRobot*

## Specifications

Module Power	+5.00 V
Measuring Temperature	0-60°C
Response Time	Less than 1 minute
Measuring Range	0-14 pH
Accuracy	$\pm 0.1\text{pH}$

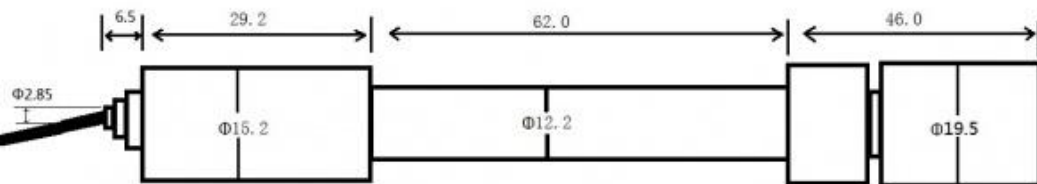

*pH Electrode Dimensions (in mm) from DFRobot*

# pH Meter Kit Schematic

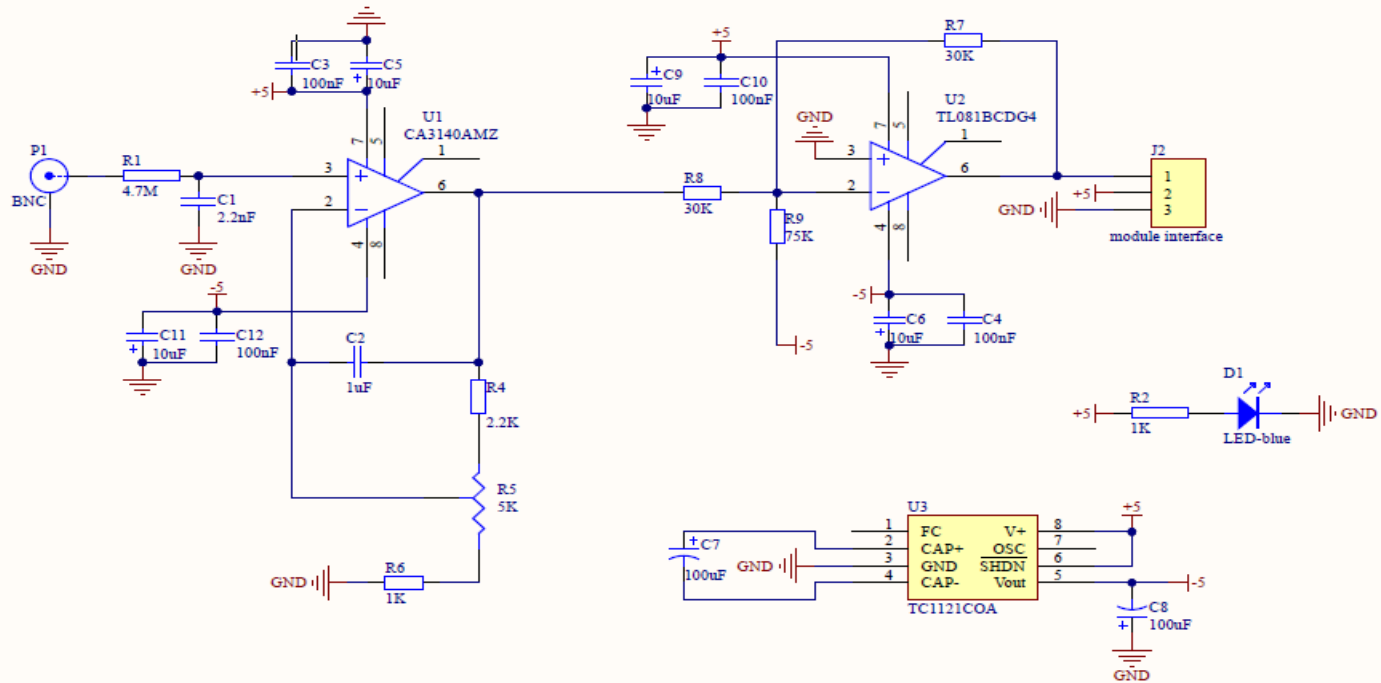

Schematic from Analog pH Meter Kit data sheet

# Electrical Conductivity (EC) Kit

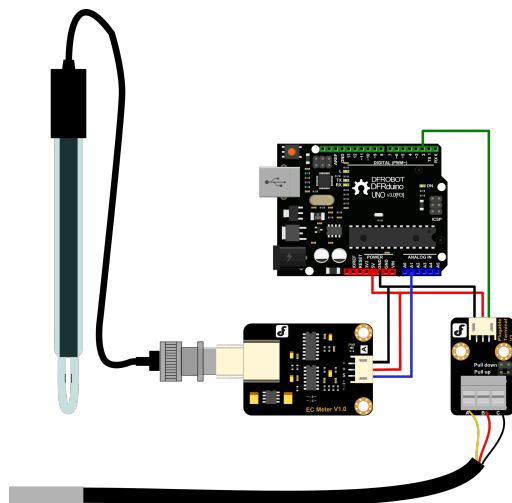

Connecting Diagram from DFRobot

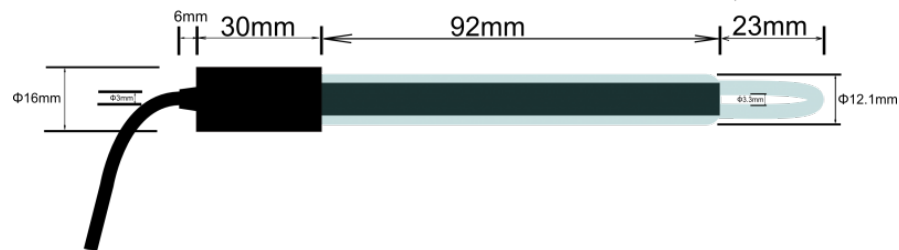

EC Electrode Dimensions from DFRobot

## EC Kit Specifications

Operating Voltage	+5.00 V
Measuring Range	1ms/cm -20ms/cm
Operating Temperature	5 - 40 °C
Accuracy	<math>\pm 10\%</math> F.S (dependent on calibration solution)
Module Size	43mm×32mm

# Electrical Conductivity (EC) Kit Schematic

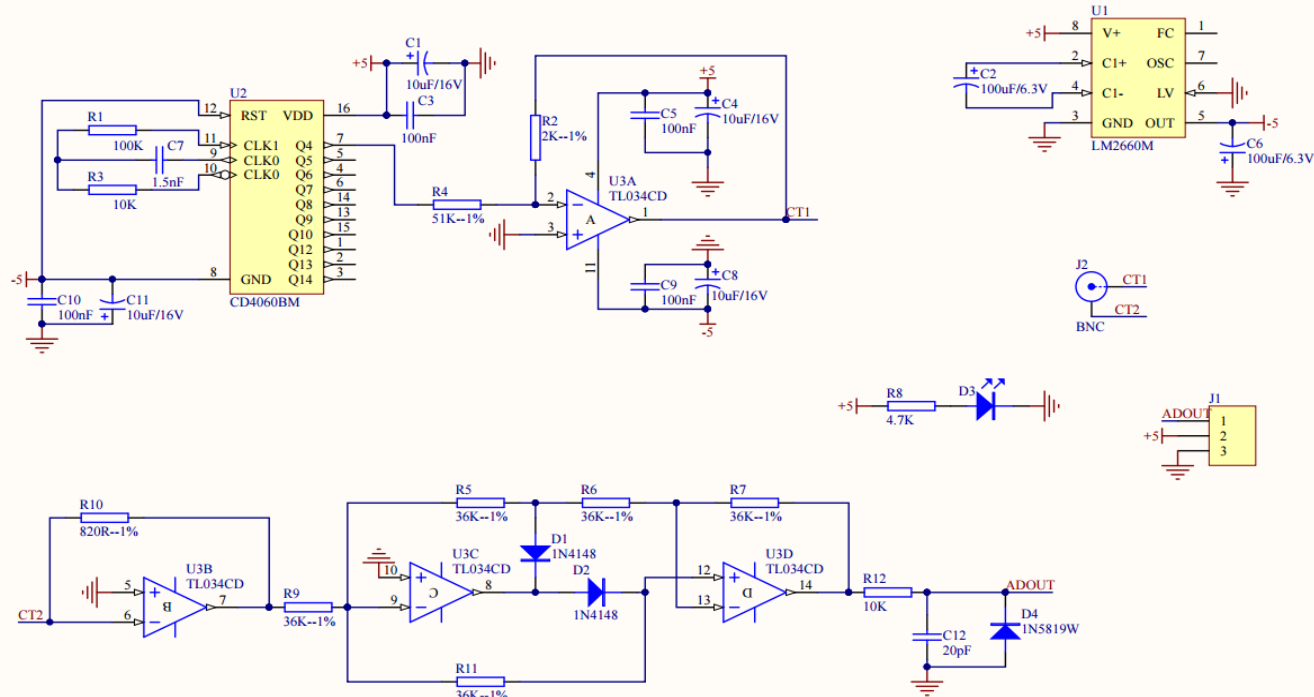

Schematic for Electrical Conductivity Kit in datasheet



# Water Level Sensor

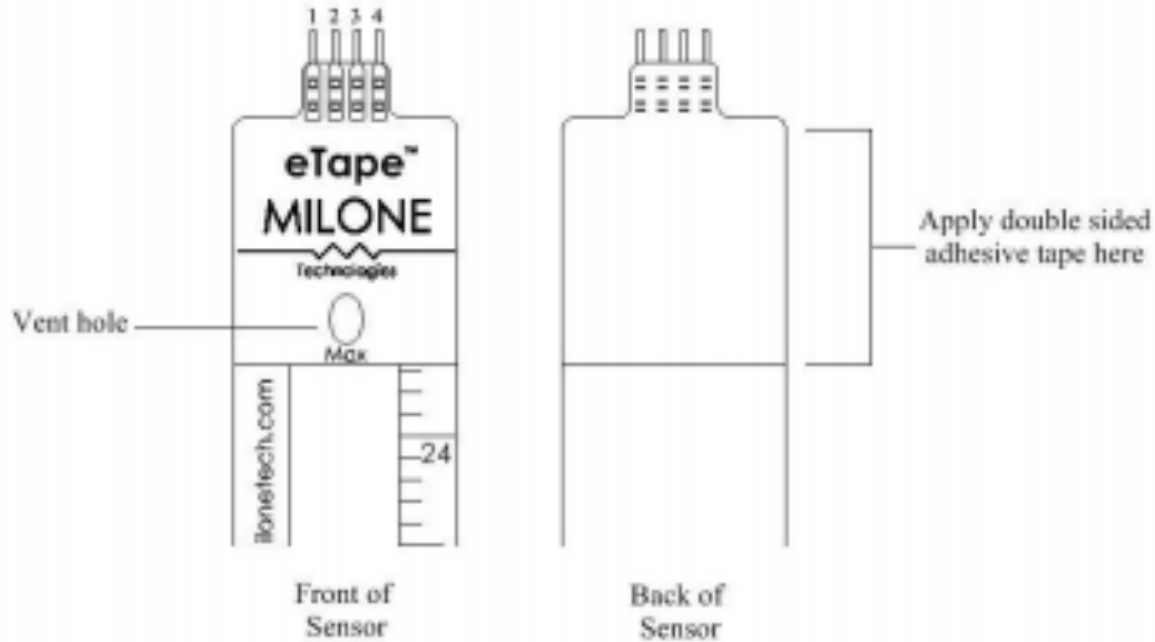

*eTape sensor layout from datasheet*

# Water Level Sensor

<b>Part Number</b>	PN-12110215TC-8	PN-12110215TC-12
<b>Nominal Length</b>	<b>8-inch</b>	<b>12-inch</b>
<b>Sensor Length</b>	10.2" (259 mm)	14.2" (361 mm)
<b>Active Length</b>	8.4" (213 mm)	12.4" (315 mm)
<b>Sensor Output</b>	400-1500 $\Omega$ $\pm$ 20%	400-2000 $\Omega$ $\pm$ 20%
<b>Ref Resistance</b>	1500 $\Omega$ $\pm$ 20%	2000 $\Omega$ $\pm$ 20%

Table from eTape sensor data sheet.

Circuit designed in Eagle CAD. Pin 2 and 3 from the eTape sensor connect to the voltage divider circuit. Pins 1 and 4 are not needed for our application of this sensor.

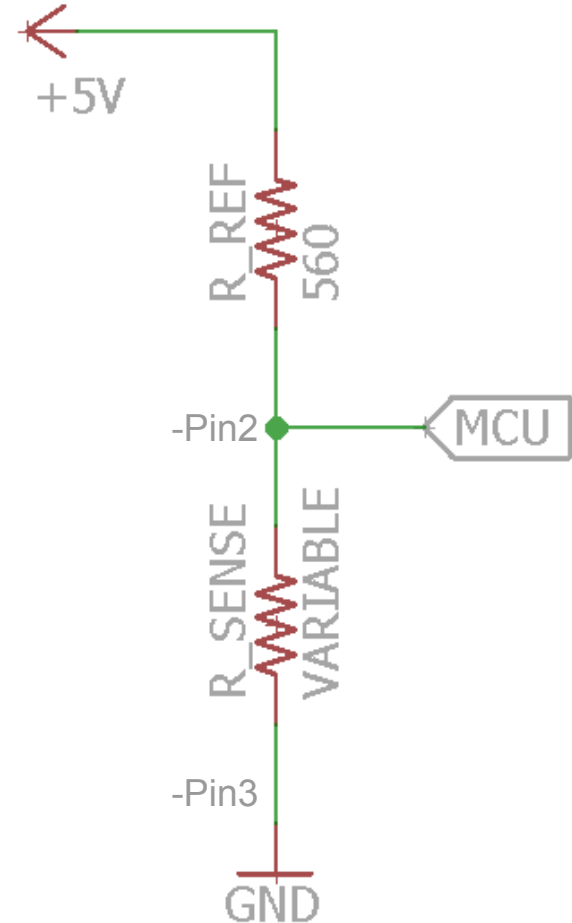

# Temperature and Humidity Sensor

DHT11 pins	
1	VCC
2	DATA
3	NC
4	GND

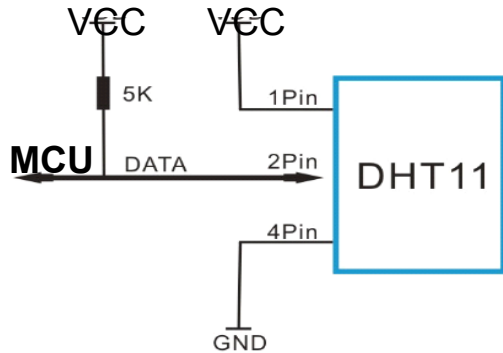
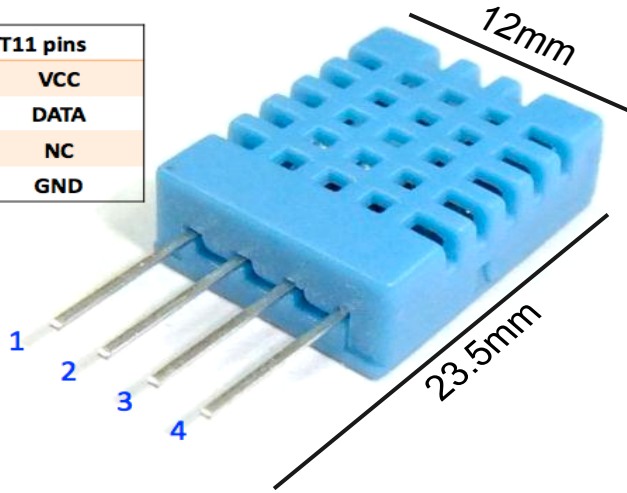

## Temperature and Humidity Sensor Specifications

Measurement Range	20 - 90% RH (Relative Humidity) @ 0 - 50°C
Temperature Accuracy	Min: $\pm 1^{\circ}\text{C}$ Max: $\pm 2^{\circ}\text{C}$
Temperature Response Time	Min: 6s Max: 30s
Humidity Accuracy	Condition 0°C-50°C Max: $\pm 5\% \text{RH}$
Humidity Response Time	Min: 6s Typical: 10s Max: 15s

*Circuit from DHT11 datasheet*

# Sensor Interaction



Check pH

Within Range

Too high / Add pH Down

Too low / Add pH Up



Check EC

Within Range

Add Nutrient Solution

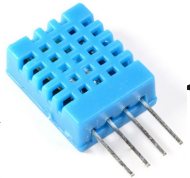

Check Temp

Within Range / Turn off fan

Too hot / Turn on Fan

Check Humidity

Within Range / Turn off Dehumidifier

Too humid / Turn on Dehumidifier



Check Level

Within Range

Too low / Send Notification to the User

# Peripherals

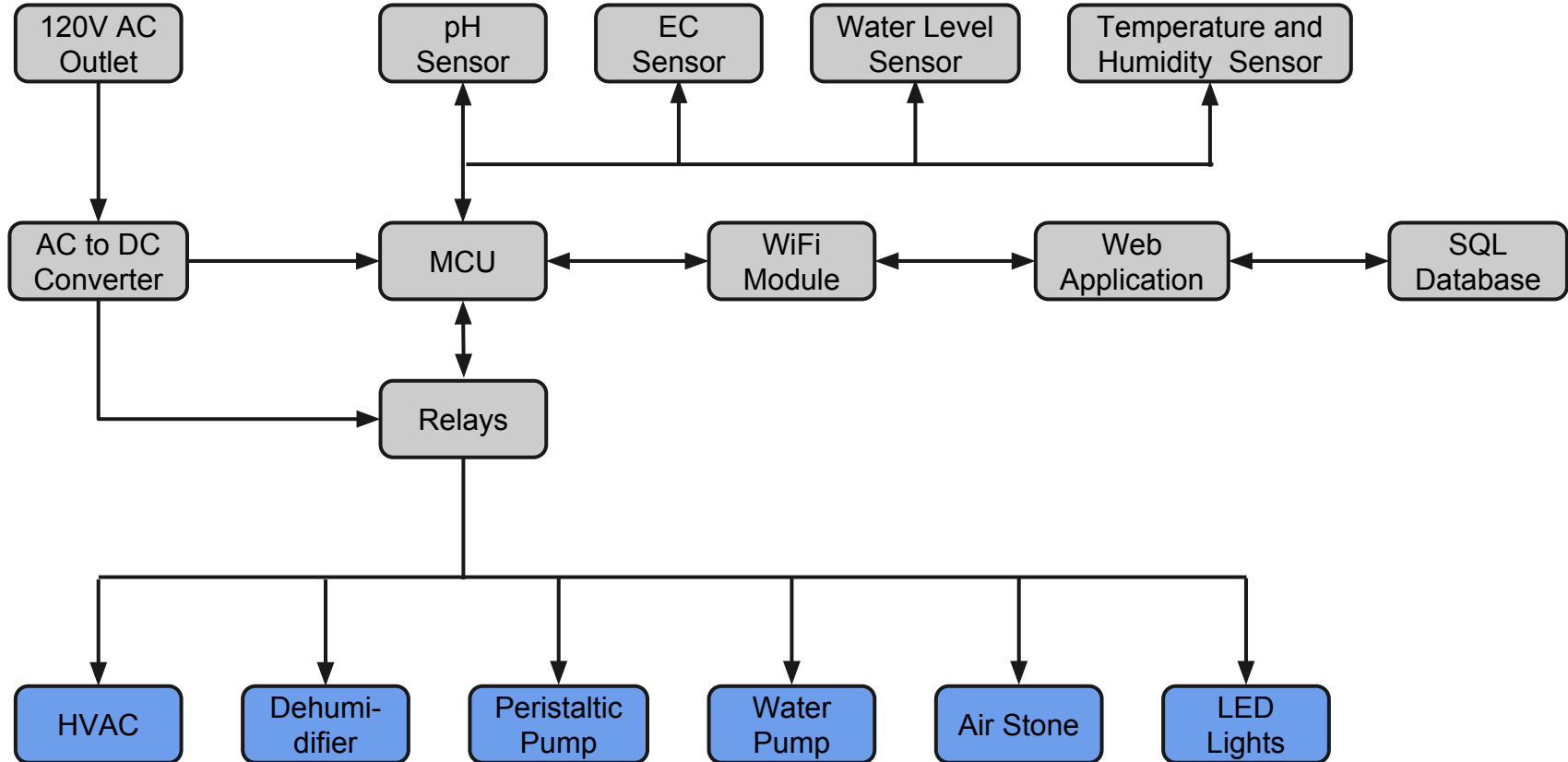

# Lights

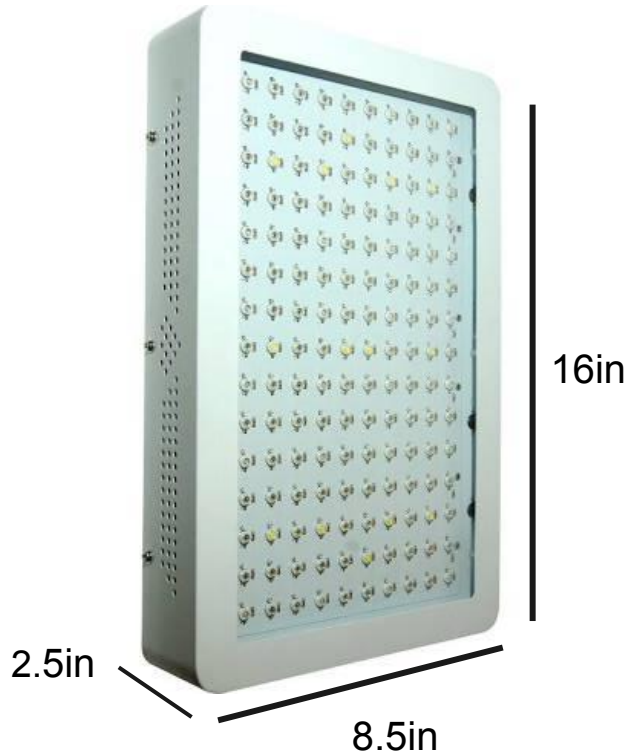

A full spectrum LED light panel will be the plant's main source of energy. The lights will run on an 18 hours on / 6 hours off, or 12 hours on / 12 hours off cycle to mimic natural sunlight.

Specifications	
Power	180 Watts
Input	110V / 60Hz
LED Lens Angle	90°
Light Coverage	7.5ft <sup>2</sup> (3' X 2.5')



# Lights

Type	Lifespan	Avg. Temperature	Distance From Plants	Efficiency	Cost
HID Grow Lights	10,000 hours	600 degrees F	6" – 10"	125 lumens per watt	~\$15 per bulb
HPS Grow Lights	18,000 hours	500 degrees F	4" – 6"	140 lumens per watt	~\$150 per bulb and ballast
LED Grow Lights	50,000 hours	70 degrees F	10" – 16"	25 lumens per watt	~\$200 per square foot panel
T8 Fluorescents	25,000 hours	100 degrees F	2" – 4"	90 lumens per watt	\$3 – \$5 per bulb

# HVAC

The backdraft damper remains closed until the exhaust fan is turned on. Once on, the damper opens allowing cool air to enter and warm air to exit. Cycles air 5 times per min.

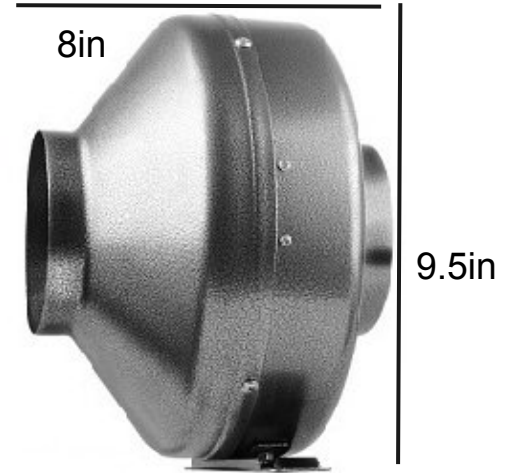
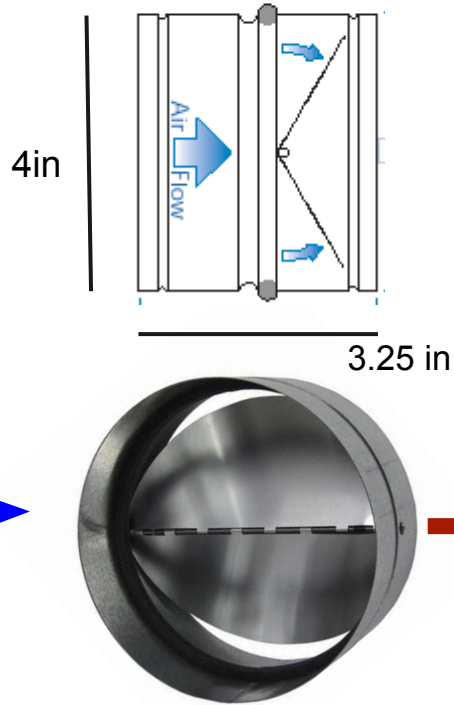

Air Flow	190 CFM
Duct Size	4 inches
Fan Speed	2565 RPM
Power	65 watts
Input	AC 110v/60Hz



# Dehumidifer

The dehumidifier will balance the environment's climate and dehumidify the space inside the enclosure. The water collected from this item will be filtered back into the reservoir to create an efficient way of keeping water levels high in the hydroponic system.

Eva-Dry 1100 Petite Dehumidifier	
Capacity	16 oz
Work Area	1100 Cubic feet
Effectiveness	approx. 8 oz at 86°F and 80% Humidity
Power	22.5 watts
Input	9V DC at 2.5 Amp



# Water Pump

- For hydroponic systems, it's recommended to turn over 100% of the water every 2 hours
- We decided to use the AAPW400 model so that we can pump the proper amount of water while compensating for the vertical distance it needs to push the water
- Pump runs on standard 120V from the wall outlet, and will be switched on/off by a relay switch in case of maintenance

**ACTIVE AQUA SUBMERSIBLE PUMP COMPARISON CHART**

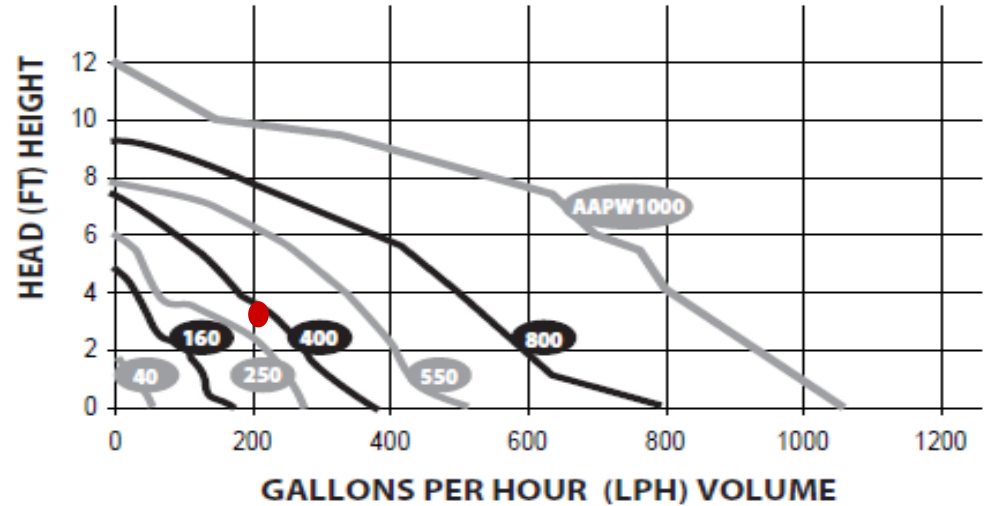

Product Item Code	Rated GPH	Rated (LPH)	Recommended Size gallons	Recommended Size (litres, litros)	Watts	Fitting Sizes Included inches	Fitting Sizes Included (millimeters)
AAPW40	43	(163)	5	(19)	3	5/16"	(8mm)
AAPW160	172	(650)	15	(57)	9.5	1/2"	(12.7mm)
AAPW250	291	(1,100)	25	(95)	16	1/2", 3/4"	(12,7mm, 19mm)
AAPW400	370	(1,400)	40	(151)	24	1/2", 3/4"	(12,7mm, 19mm)

# Peristaltic Pumps

- Runs on 12V DC supply draws 200mA
- Small 5mm diameter tubes
- When activated, 1mL/s of solution is delivered to the flow
- Flow can be altered by increasing or decreasing the voltage to the dosing pumps

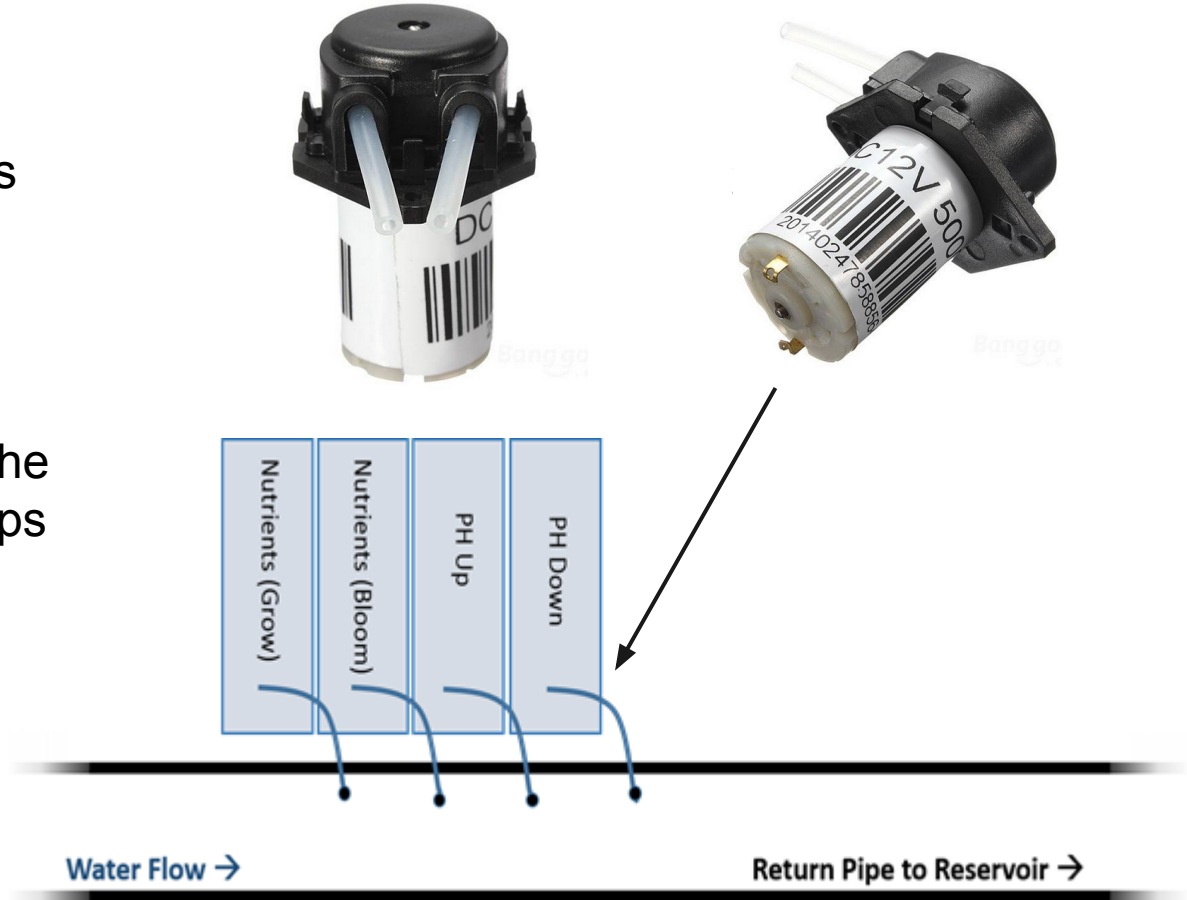

# Air Pump

- Within our water reservoir, we will have an air pump that will push air out of an air stone placed at the bottom of our water reservoir
- Will produce bubbles that will aerate the system's nutrient solution
- This is important so that the plants' roots can readily absorb the oxygen they need through their water



# MCU

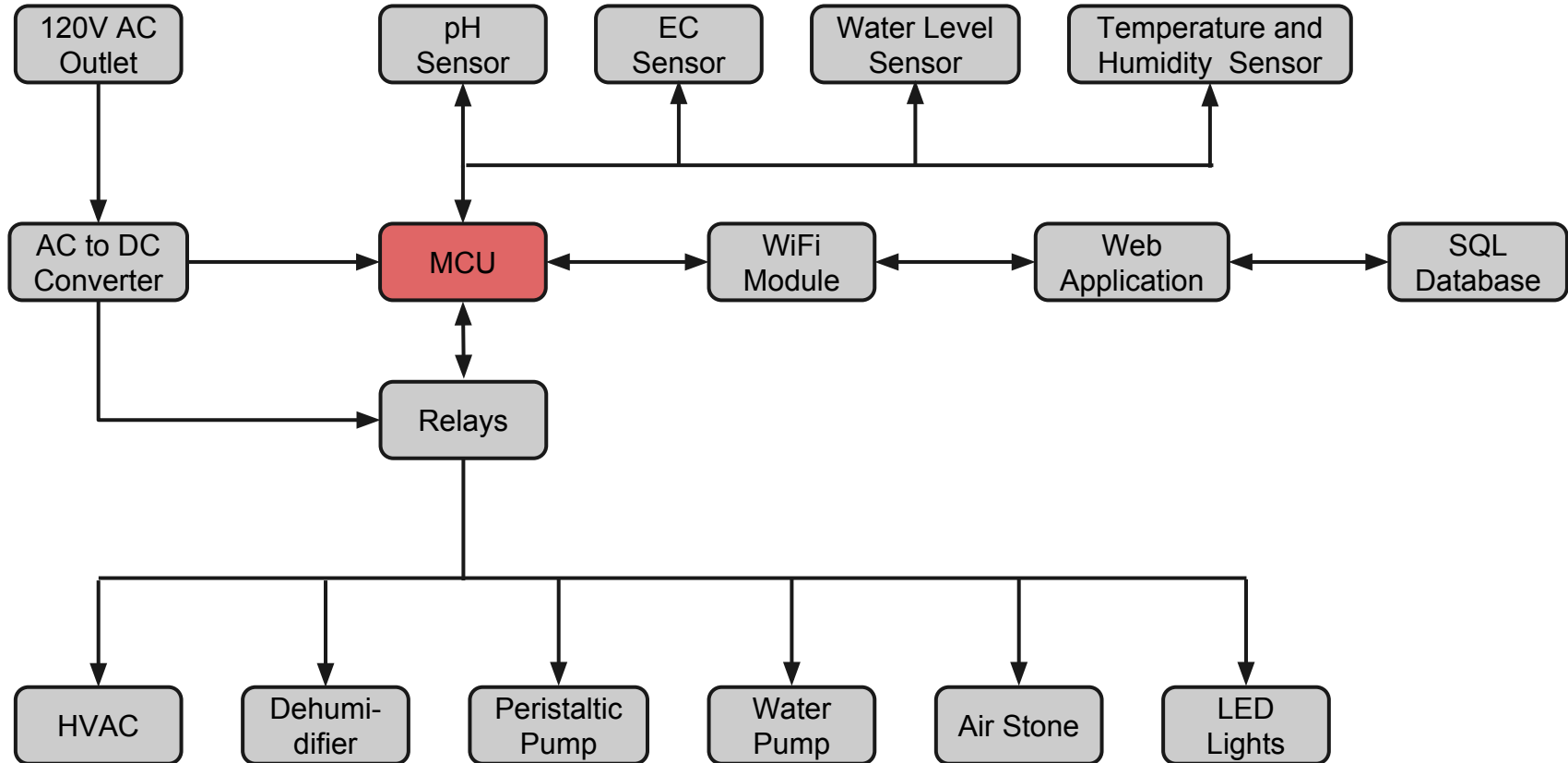

# ATMega 2560 vs. MSP430F5659

## Atmel ATMega 2560 Specifications

Parameter	Value
Flash Memory (Kbytes)	256
Pin Count	100
Max Operating Frequency (MHz)	16
Operating Voltage	Min: 1.8V Max: 5.5V
Max I/O Pins	76
SPI	5
I2C	1
UART	4
Coding Environment	Arduino IDE

## TI MSP430F5659 Specifications

Parameter	Value
Flash Memory (Kbytes)	512
Pin Count	100
Max Operating Frequency (MHz)	20
Operating Voltage	Min: 1.8V Max: 3.6V
Max I/O Pins	74
SPI	6
I2C	3
UART	3
Coding Environment	Code Composer Studio

# Power Components

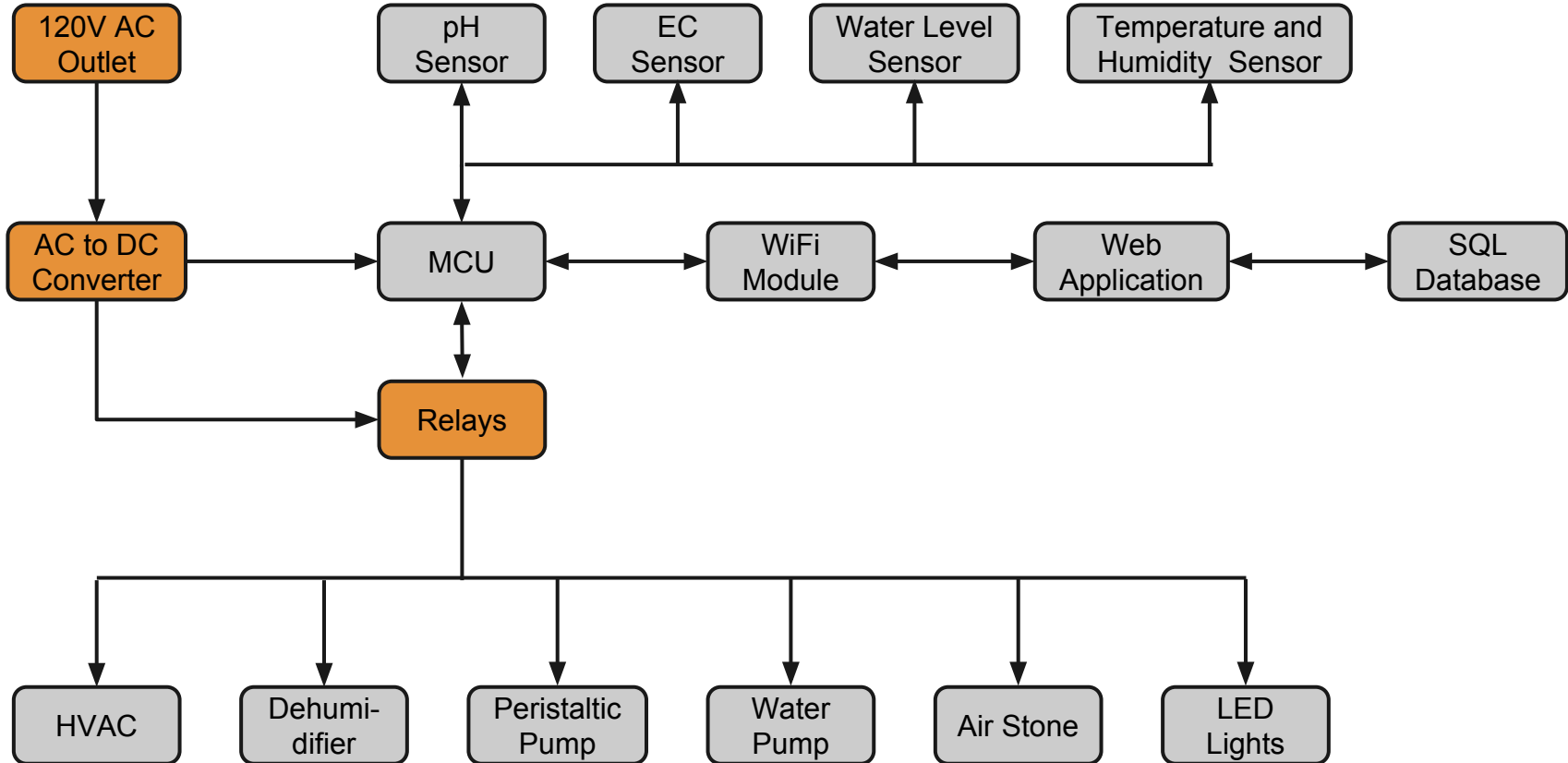

# AC to DC Converter

A standard wall mounted AC to DC converter will be used to power the PCB. Total current draw of PCB IF all components were on would be just over 1.08Amps.



Specifications	
Input	110VAC / 60HZ
Output	12 V @ 1.5Amps
Jack size	2.1mm



# AC to DC schematic

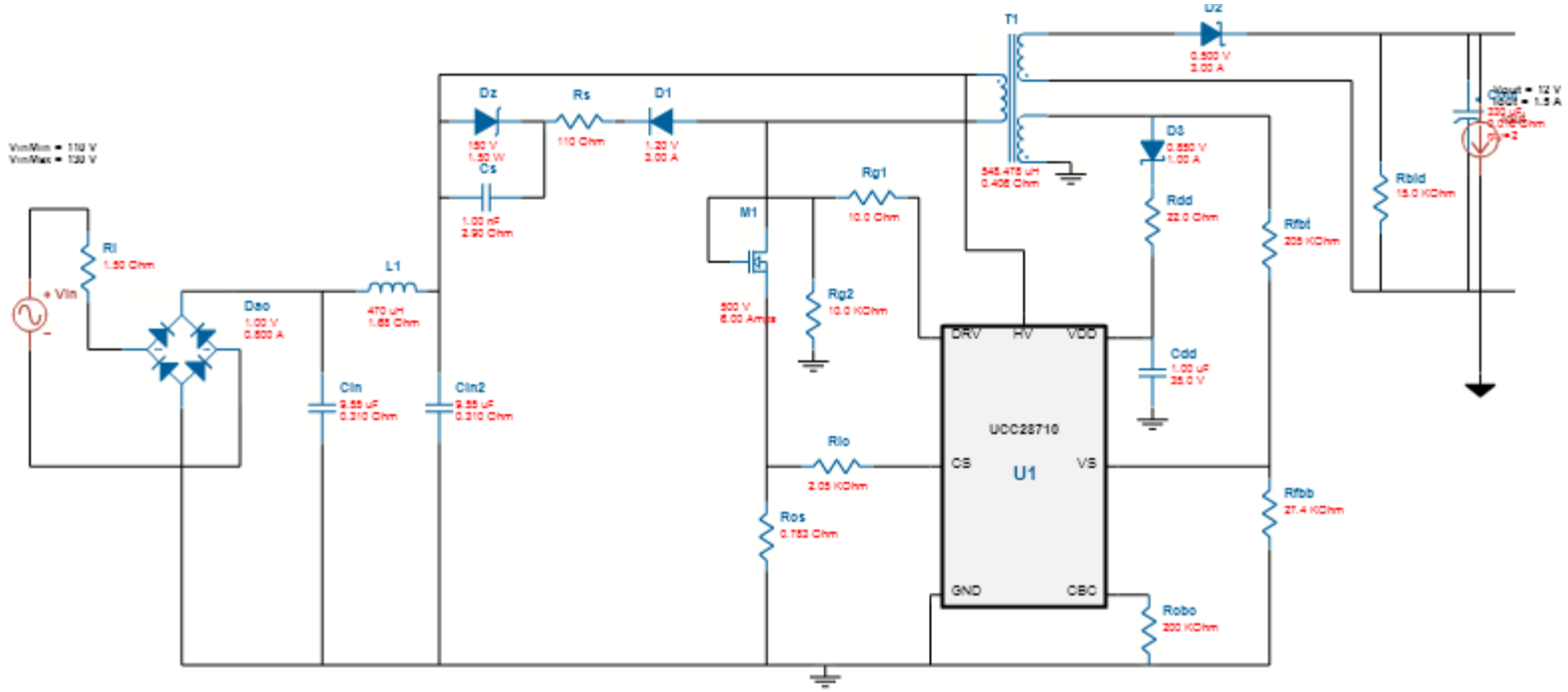

110VAC 60Hz input to 12V @ 1.5Amp output schematic, TIwebench

# DC to DC converter

Linear voltage regulators are used to supply the smaller voltages through the PCB and save board space.

12 Volts  
relays  
Peristaltic pump  
motors

5 Volts  
MCU  
EC sensor  
pH sensor  
Water level sensor  
Temperature and  
humidity sensor  
Wifi Module

3.3 Volts  
Extra

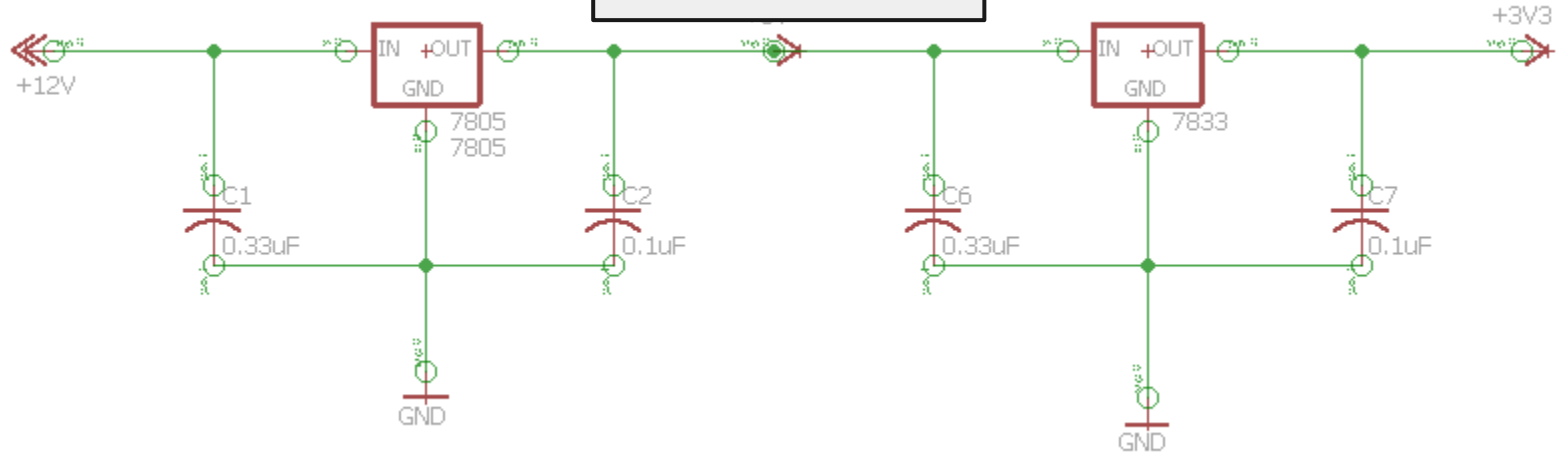

# Relays

Relays will be used to turn on or off the high power components; LED light, Exhaust fan, Air+Water pump, and the dehumidifier.

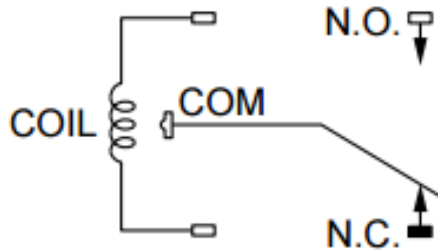
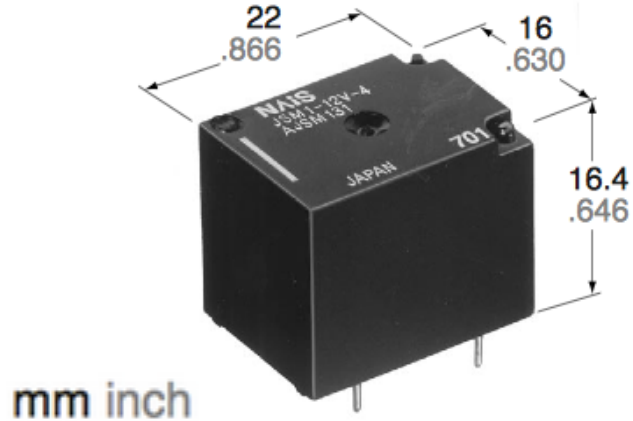

Specifications	
Coil Voltage	12 volts
Coil Resistance	400Ω
Contact rating	10A / 125VAC
Trigger Time	5-10ms

# Relay and motor driver

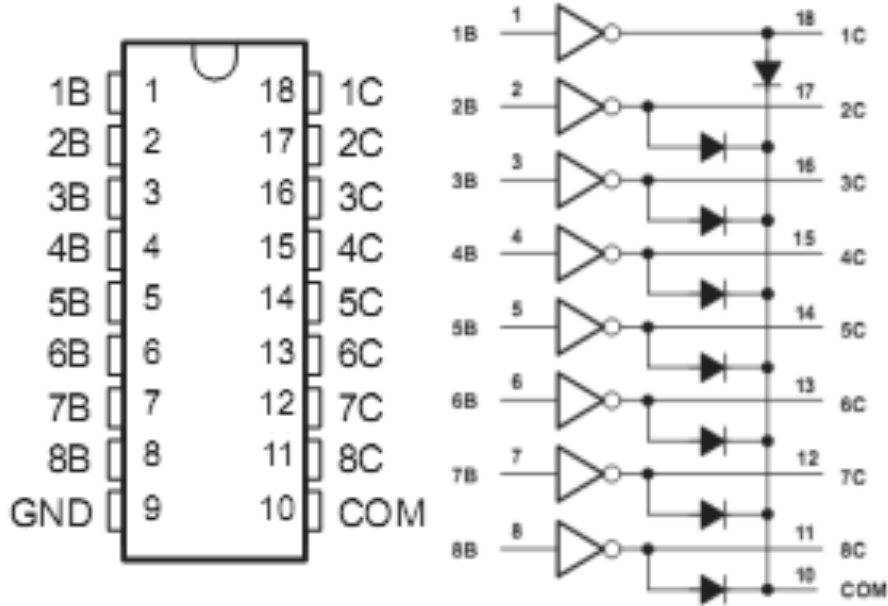

*ULN2803 chip and schematic from TI datasheet*

A ULN2803 Darlington Transistor array will be used as the relay and motor driver. 8 NPN darlington Pairs with high voltage and current output, as well as common cathode clamps for protection from back current when the inductive loads are switched off.

Specifications	
Input Voltage (COM)	30 Volts max
Trigger Voltage	5 Volts max
Output Current	500mA max

# Power Strip

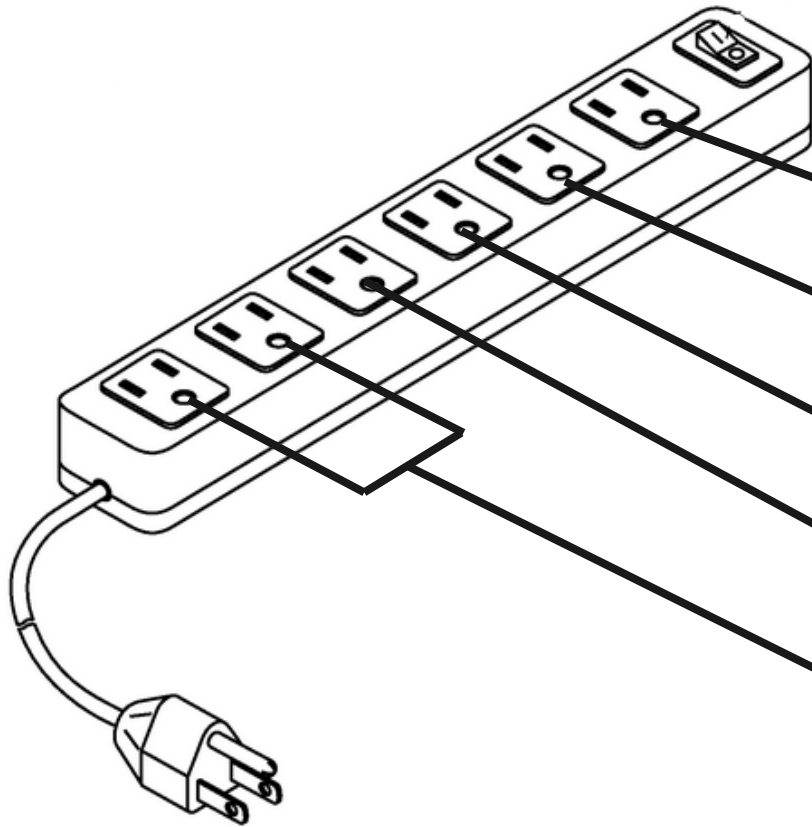

4 Relays will control 4 outlets while 2 will remain always on.

LED Lights

Exhaust Fan

Air+Water Pump

Dehumidifier

Always ON

# PCB Design

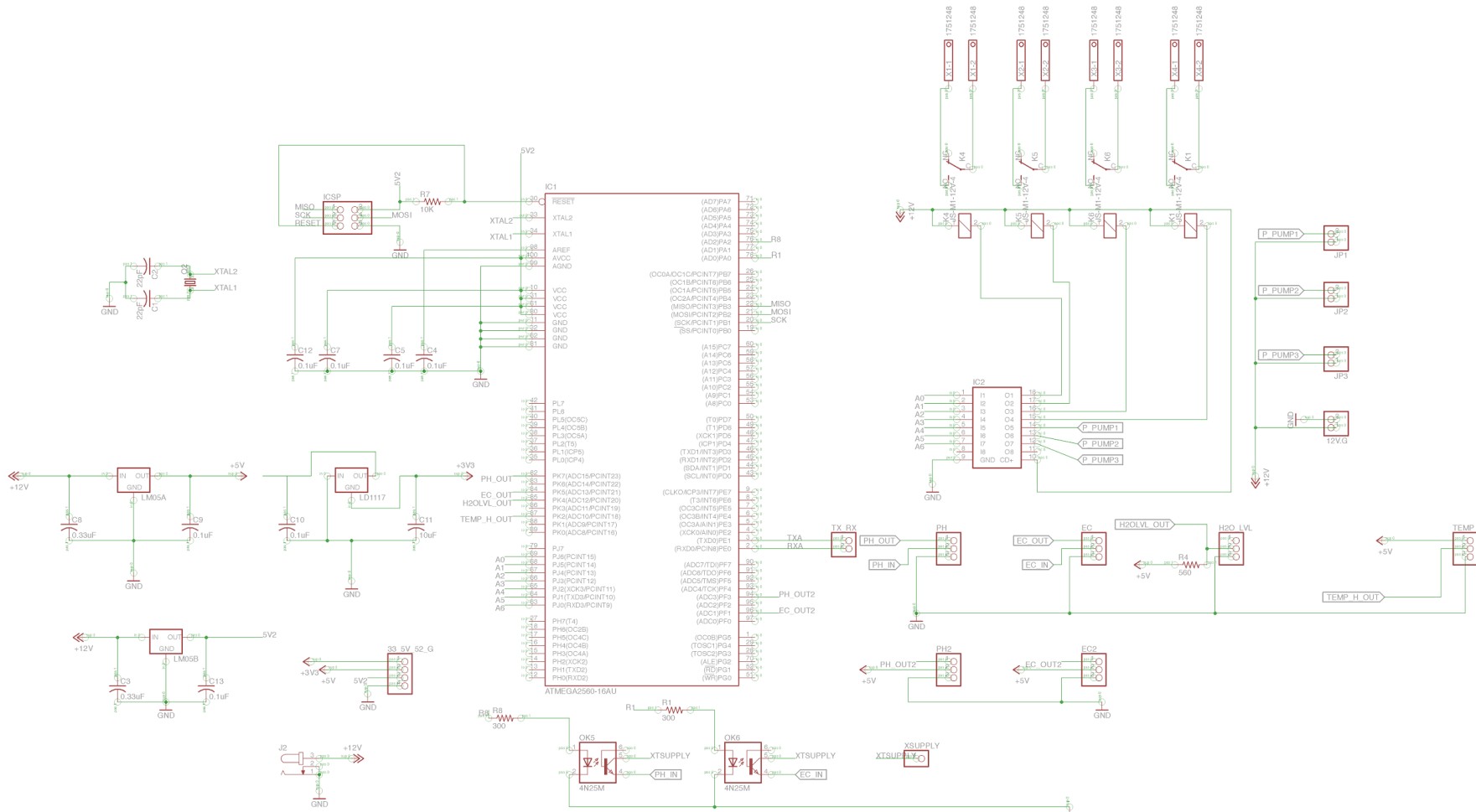

# PCB

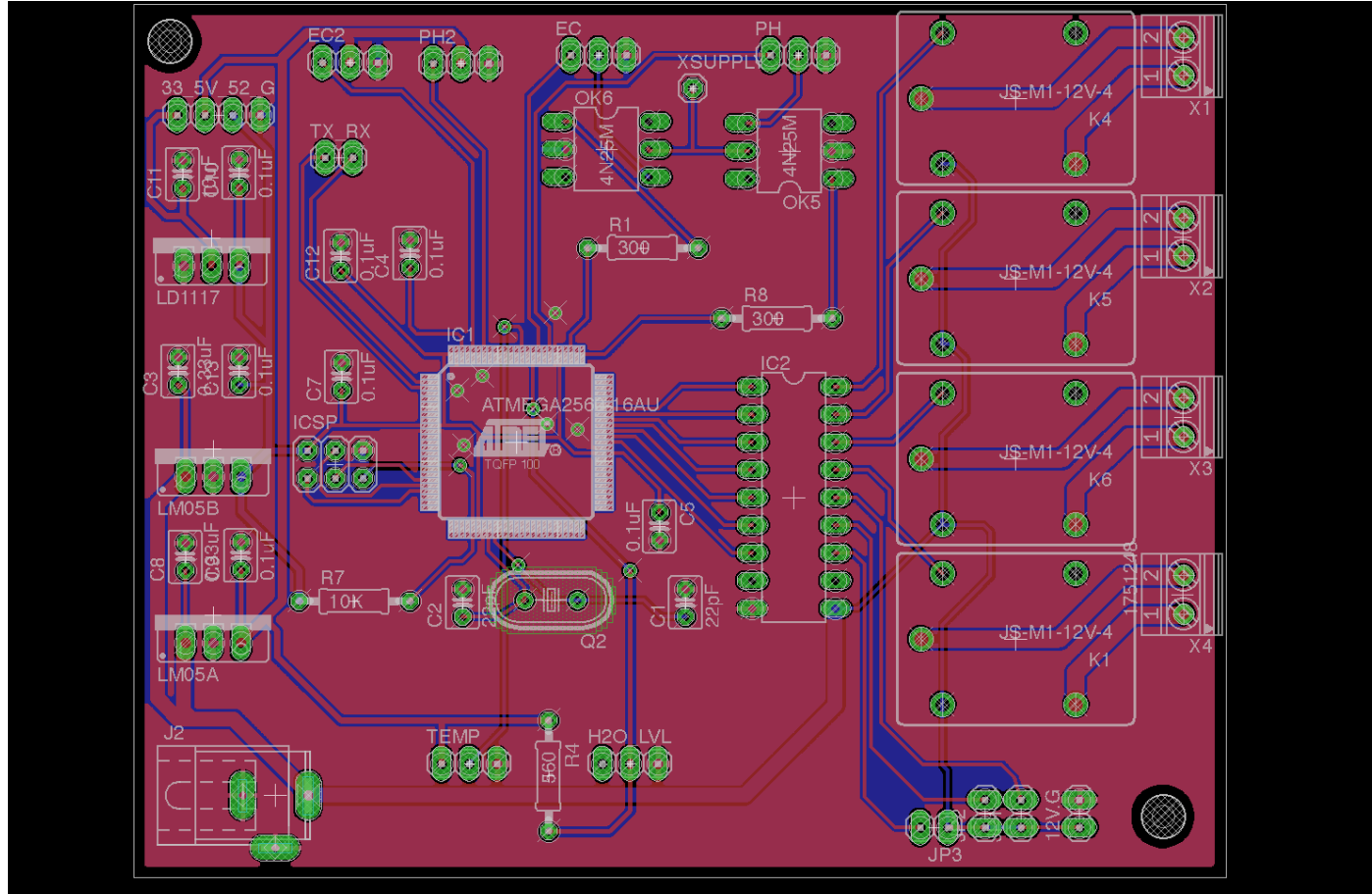

# PCB

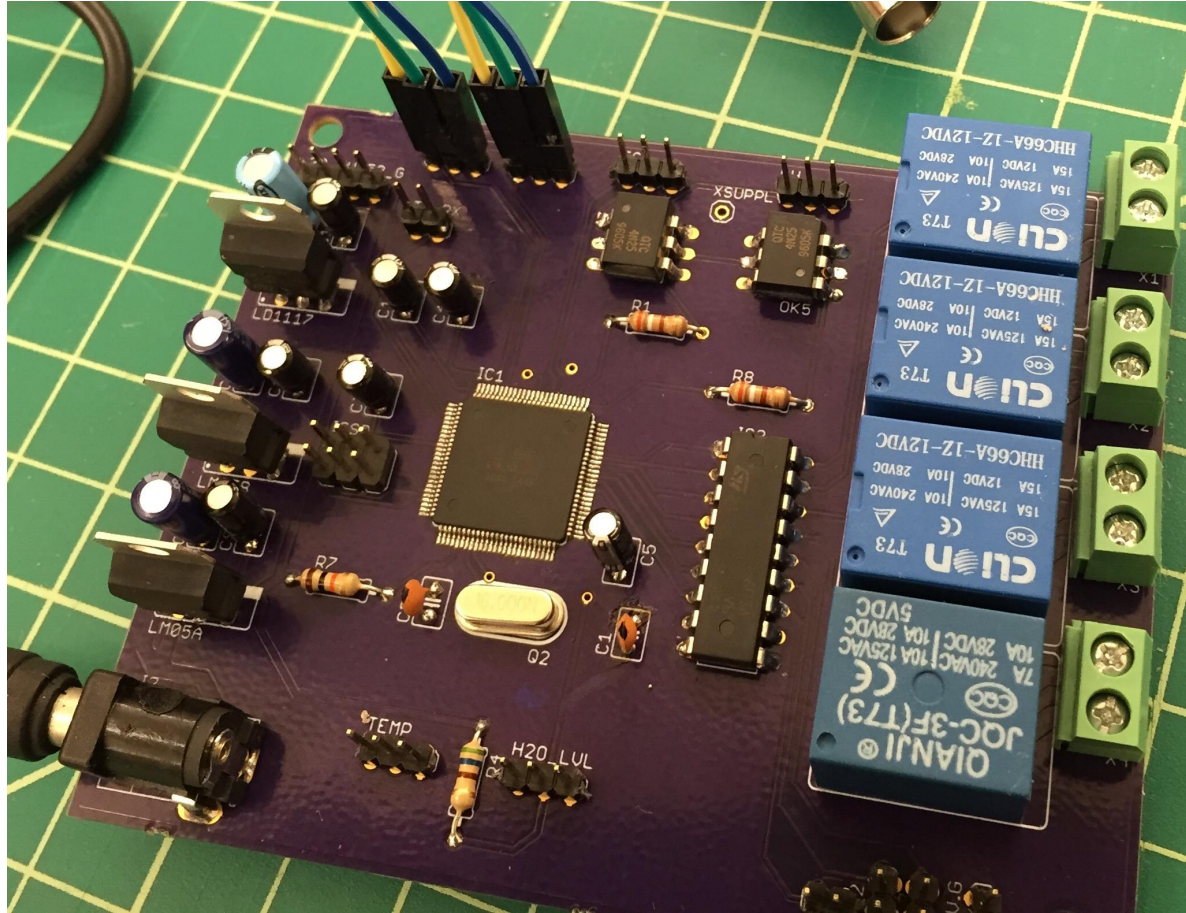



# Web Application

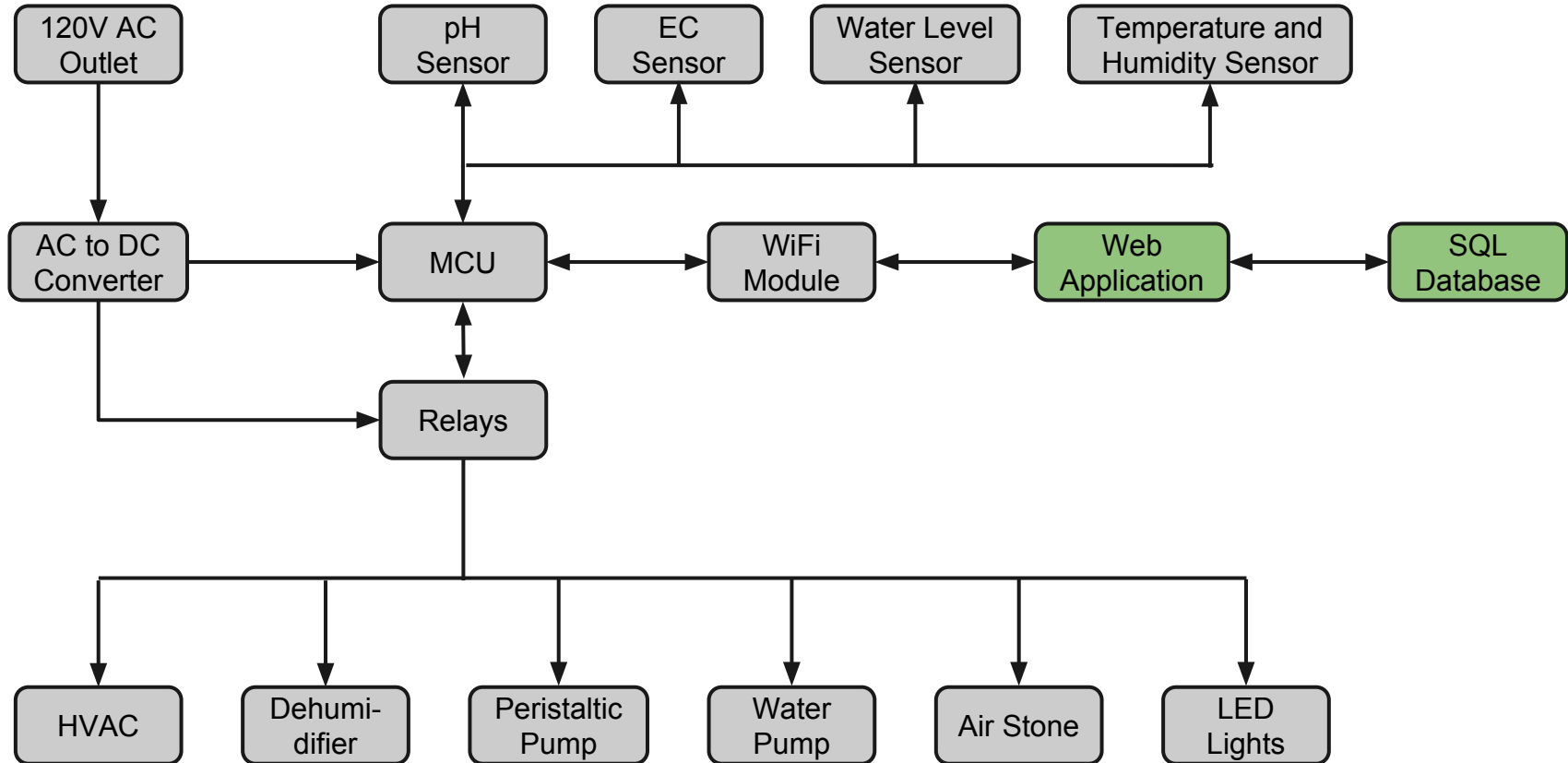

# Database

SQL Database Design:

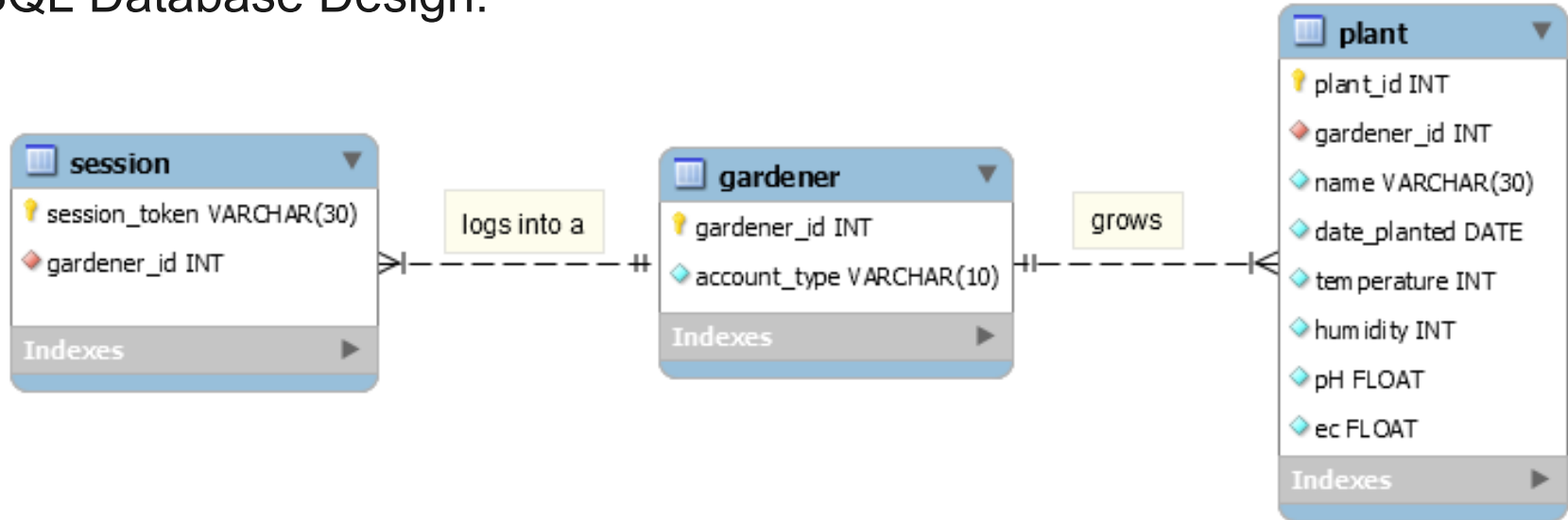

Creating an open source database for users to share their optimal environment conditions with others.

# Mobile App vs. Web App

## Mobile App:

- Cross-platform coding
  - iOS
  - Android
- Uses storage space on mobile devices

## Web App:

- Reaches all devices through internet
  - Support through different browsers, only the latest (safari, chrome, firefox)
- All data will be accessed through internet

# Web App Features

HostGator.com Control Pa x AutoBott - Automated Inc x Beginning Arduino: delay x ATmega2560 x

ucfautobott.com/index.html

Dashboard Database About Team

## AutoBott

The next big thing is here! A fully automated indoor botanical smart garden, where the enclosed environment and hydroponics system is monitored and automatically adjusted 24/7.

### Essential Items Used In AutoBott

- Analog pH Meter Kit
- Analog EC Meter Kit
- Temperature & Humidity Sensor
- LED Lights
- Hydroponics System
- HVAC System

### Motivation

The AutoBott was created with the intentions of minimizing water and power usage in an atmosphere where those resources are scarce.

[View details »](#)

### Environment

The environment and climate is manipulated to be perfect conditions for any type of plants growing inside the enclosure.

[View details »](#)

### Hydroponics

The system that provides a source of food and energy to optimize growing conditions for the plants inside the enclosure.

[View details »](#)

# Web App Responsiveness

- The web app is created using Bootstrap, which is a mobile-first development tool
- The AutoBott web app is responsive with devices that have different size screens.

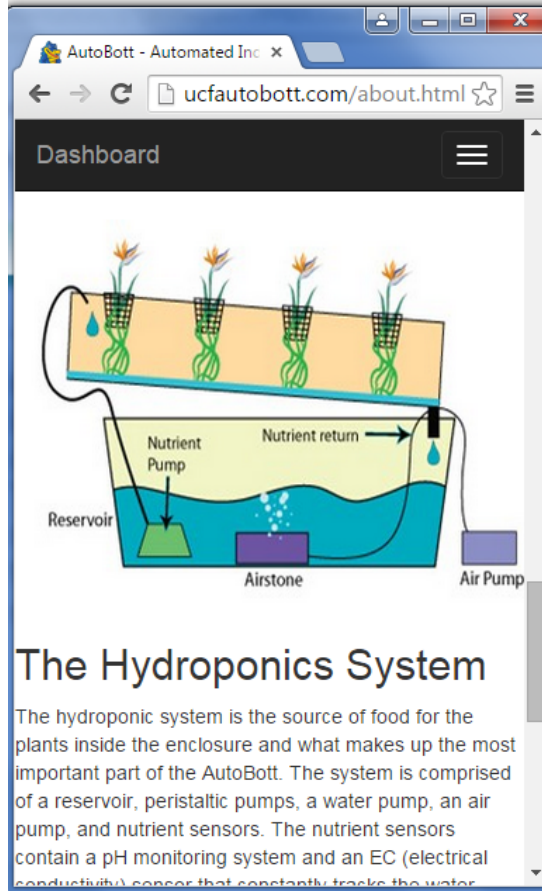

AutoBott - Automated Inc x  
ucfautobott.com/about.html

Dashboard

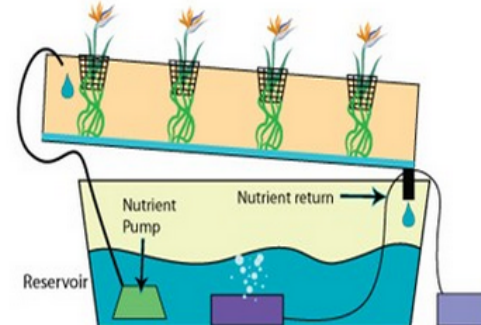

**The Hydroponics System**

The hydroponic system is the source of food for the plants inside the enclosure and what makes up the most important part of the AutoBott. The system is comprised of a reservoir, peristaltic pumps, a water pump, an air pump, and nutrient sensors. The nutrient sensors contain a pH monitoring system and an EC (electrical conductivity) sensor that constantly tracks the water

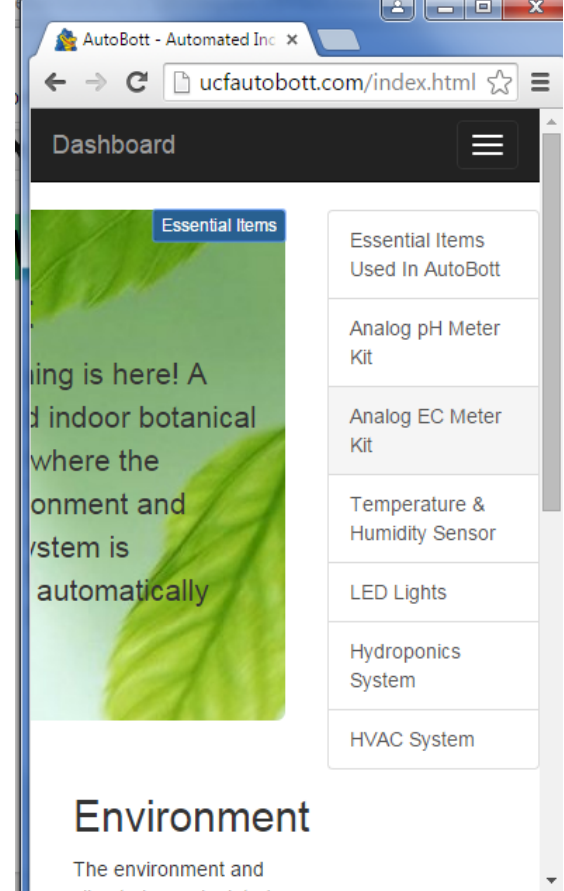

AutoBott - Automated Inc x  
ucfautobott.com/index.html

Dashboard

Essential Items

Essential Items Used In AutoBott

- Analog pH Meter Kit
- Analog EC Meter Kit
- Temperature & Humidity Sensor
- LED Lights
- Hydroponics System
- HVAC System

**Environment**

The environment and

# Testing - Software

## Sensor

- Each sensor individually
- Sensors paired
- All sensors

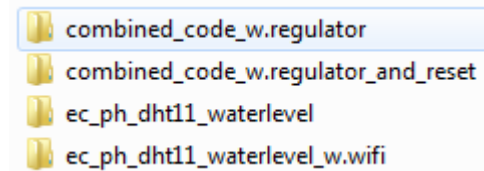
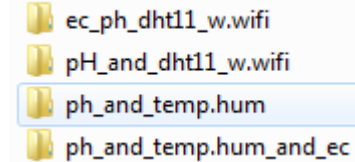
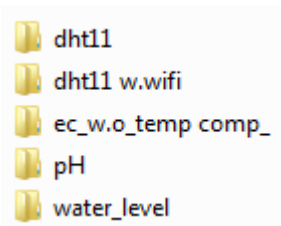
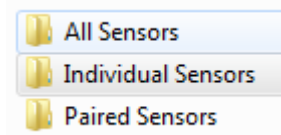

## Website and Wifi

- Database
- Interfacing with wifi and localhost
- Website functionality using bootstrap
- Website updates automatically

# Testing - Hardware

## PCB prototype (breadboard)

- Relays
- Solid State Driver
- Optocouplers
- Voltage dividers
- Sensor power

## Infrastructure

- Stable enough to withhold a 25lb reservoir among other components
- Air tight (vacuum enabled)

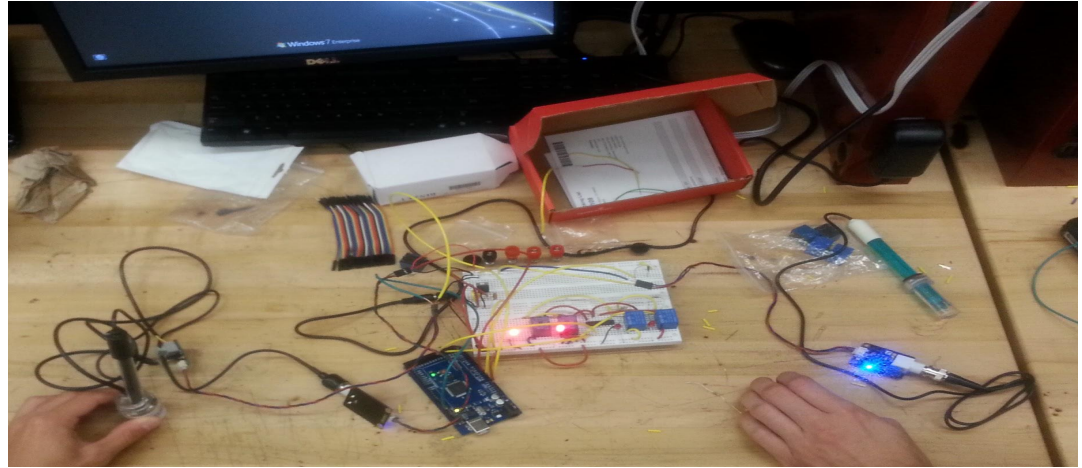

# Testing - PCB and Integration

## PCB

- Microcontroller (malfunctioned)
- Power distribution

## Integration

- Placement/positioning of devices and components in the enclosure
- PCB powers system
- Sensors accurately take readings in reservoir and trigger corresponding components

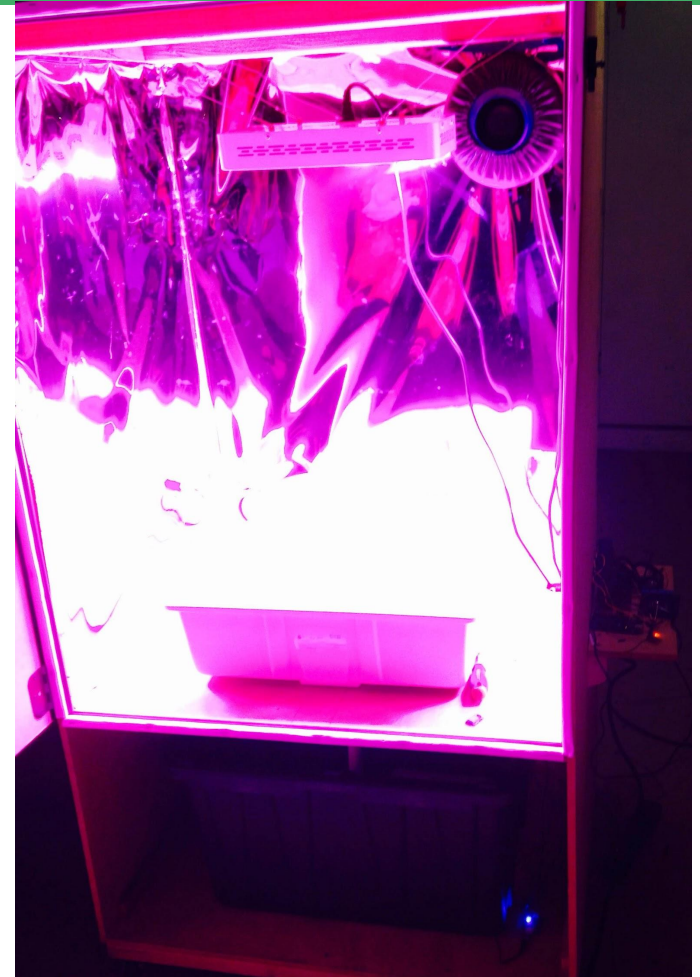



# Administrative Content

## Work Distribution:

<b>AREAS OF WORK</b>	<b>David</b>	<b>Antonio</b>	<b>Eric</b>	<b>Steven</b>
Power Supply and Distribution		X	X	
Web Application	X			X
PCB Design		X	X	
Sensor Interaction			X	X
MCU Programming	X			X
Hydroponic Research and Design	X	X		
Enclosed Environment Design			X	X
Physical Enclosure Design	X	X		

# Budget

Subsystems	Parts and Materials	Quantity	Unit Cost	Cost
Sensors	pH sensor	1	\$38.00	\$38.00
	EC sensor	1	\$76.00	\$76.00
	Water level sensor	1	\$43.00	\$43.00
	Air temp. and Humidity sensor	1	\$7.00	\$7.00
	Infrastructure	Oriented Strand Plywood	5	\$25.00
	Door Hinges	1	\$8.00	\$8.00
	Wires, cables, tubing	1	\$16.00	\$16.00
	Wheels	1 (set)	\$9.80	\$9.80
Components	MCU's (Atmega2560)	2	\$24.00	\$48.00
	Arduino Dev Board	1	\$16.00	\$16.00
	Solid State Relays	4	\$1.00	\$4.00
	Darlington Driver 8 Channel	1	\$9.99	\$9.99
	Wifi module	1	\$50.00	\$50.00
	LED lights	1	\$98.95	\$98.95
	Power circuit materials (power strip)	1 (set)	donated	\$0.00
	Air stone	1	donated	\$0.00

Main	Water pump	1	\$29.00	\$29.00
	HVAC	1	\$65.00	\$65.00
	De-humidifier	1	\$41.00	\$41.00
	Reservoir	1	discounted	\$12.00
	Nutrient pump	4	\$10.00	\$40.00
	Grow pots	5	\$1.20	\$6.00
	Plant trays	1	discounted	\$40.00
Extra	Nutrients	4 (set)	sponsored	\$0.00
	Mylar	1	\$10.00	\$10.00
	ICSP (programmer)	1	\$43.00	\$43.00
	Grow rocks	1	\$10.00	\$10.00
	Unaccounted materials	variable	n/a	\$50.00
			<b>Total Cost</b>	<b>895.74</b>

**Total Cost: \$895.74**

# Financing

Sponsored by Urban Sunshine - Organic and Hydroponic Gardening

Location: Orlando

- Contributed nutrients for free
- Grow trays were given at a discounted price

Otherwise, every other component in project was funded by group.

# Issues

- Making cabinet air sealed
  - None of our strong suits
- Ensuring plant sensors are not tampered with remotely
  - Security
- Wireless module able to transmit to localhost machine but not to a domain name located on another server
  - Port forwarding
- Microcontroller GPIO pins were mapped incorrectly
  - Recovered using original dev kit with same Atmel chip

# Questions

